

TECHNICAL DATA SHEET

LPI[®] GUARDIAN SYSTEM 5

- Fully Tested Air Terminals in Compliance with IEC 62561-2
- Family of Stainless Steel Air Terminals catering for all installation heights
- Easy to Install
- All Guardian CAT Terminals utilise a blunt finial tip for corona minimisation
- Cost Effective Lightning Protection
- Free Lightning Protection Designs & Risk Assessments Available on Request
- For connection to HVSC Plus or 2-inch GI pipe
- See Page 2 for Market-Leading Advantages

Market Leading Advantages

TECHNICAL DATA SHEET

LPI's award-winning families of enhanced air terminals have the following key characteristics:

- First company to introduce corona-minimising terminals with optimised blunt design and four independent panels;
- Extensive field experience with more than 50,000 installations over 15+ years in more than 75 countries around the world;
- Air terminal families designed to meet direct-strike placement methodologies in compliance with various international standards; and
- Proven technology based on international research findings, modelling and field testing.

Lightning Protection International Pty Ltd (LPI) was established by its principals in 2002 on the back of decades of experience in the lightning protection industry worldwide.

Recognising the need for reliable air terminals and having innovation as a core value of the company, LPI released its first range of air terminals based on a "blunt" configuration with an overall geometric design for reducing corona formation during the pre-stroke phase of a thunderstorm.

The detrimental effect of excessive pre-stroke corona space charge was first postulated by Prof. C. Moore et al in the USA in the 1990s. The theory was backed by the world's most extensive field experiment of its kind on a high mountain in New Mexico. His experiment has been running for more than 20 years and has proven conclusively that blunt air terminals are more effective at lightning capture than the original sharp rods proposed by Benjamin Franklin in the mid-1700s.

LPI was the first company in the world to release a "family" of air terminal with blunt tips and the corona-reduction concept flowing from the New Mexico experiments. All the LPI air terminal families are comprised of three sizes (small, medium and large), wherein installation of any particular size of air terminal is dictated by the height of installation.

LPI has received numerous export awards over the last 15 years for the air terminal design, including a "High Commendation" at the Australian Engineering Excellence Awards night in 2016. LPI's air terminals have had more than 15 years of proven experience in regions of the world with the highest lightning activity. More than 50,000 air terminals have now been installed. They protect a wide range of structures and facilities across all types of industries in more than 75 countries around the world.

Pre-stroke corona reduction, corona-streamer initiation and the launch of an upward leader that continuously propagates to intercept the lightning downward leader has been the major theme behind all LPI's research and development initiatives in air terminal technology. LPI air terminals also have other unique features. Such as four independent panels comprising the main body around the blunt central rod and use of materials that can withstand the harsh electrical and atmospheric environments to which the air terminals are subjected year after year.

LPI is one of very few companies in the world to offer different direct-strike placement methodologies for air terminals in compliance with various international standards.

The corona-reduction concept is now widely accepted in the lightning protection industry, as evidenced by recent publication of papers on this topic in prestigious journals by some of the world's leading lightning scientists, such as Prof. V. Cooray from Uppsala University.

TECHNICAL DATA SHEET

CATCALC Software Design

LPI® uses a CAD-based software design program called “CATCALC” to customise a cost-effective and safe lightning protection solution for any structure.

The CATCALC program considers factors such as lightning activity, height above sea level, level of protection desired or recommended (Standard, High and Very High), physical dimensions of the structure and the building materials used. Competing features, which also have the ability to launch upward leaders, are taken into consideration during the design process.

A customised CATCALC design provides the end customer with a design report encompassing elevation, plan and side views of the proposed lightning protection installation along with a detailed bill of materials for all required accessories.

Calculation Overview

The calculation of the protection radius of Guardian CAT terminals and the attractive radii of features on the structure that are most likely to be struck depend on many factors, including the geometry of the structure itself, environmental parameters and the statistics of lightning discharges.

The key factors and parameters taken into account in the calculations include: A. Protection level according to the “risk profile” of the structure (decided mainly by its height) or chosen by the customer (see table below); B. Downward leader charge distribution model and dynamic electric field of the downward leader as it approaches the structure. C. Striking distance computations using a leader propagation model that takes structure height into account and utilises capture volumes; . D. Electric field enhancement of the ambient electric field by the structure and its geometric features; E. Allowance for lightning approaching at an angle; F. Computation of striking distance surfaces for the structure and air terminals; G. The speed of the downward and upward leaders (the so-called “race condition”); H. Selection of the correct CAT terminal for the particular installation, e.g., CAT III is used at a greater height above the structure and/or on taller structures due to its larger geometry and greater ability to minimise pre-corona; I. Additional allowance for the corona-minimising characteristics of the air terminal; J. Determination of protection coverage, i.e., whether coverage is achieved based on the relative distances between the surfaces and typical leader velocities.

Based on lightning statistics from AS 1768 and IEC 62305, the following “protection levels” and their associated physical parameters are used for each of the CAT terminals in protection calculations:

Air Terminal	Protection Level	Interception Efficiency (%)	I_p min. (kA)	Charge, Q (C)
Guardian CAT I, II or III	Standard	88	15	1.5
Guardian CAT I, II or III	High	93	10	0.9
Guardian CAT I, II or III	Very High	98	6.0	0.5

LPI® Product Range

TECHNICAL DATA SHEET

LPI® GUARDIAN SYSTEM 5..... 1

Market Leading Advantages..... 1

 CATCALC Software Design..... 3

LPI® Product Range 3

 Installation Type 1..... 6

 Installation Type 2..... 7

 Installation Type 3..... 8

 Installation Type 4..... 9

 Installation Type 5..... 10

 Section A - LPI® Guardian Cat Terminals..... 11

 LPI® Guardian CAT Terminals..... 12

 Standard Adaptor..... 12

 GI Adaptor..... 12

 Guardian CAT Tester..... 12

 Section D - LPI® Inline Coupling..... 13

 Section E - LPI® Guy Kit..... 13

 Section F - LPI® Guy Ring..... 14

 Section G - LPI® Lower Mast Assembly 14

 Section H - LPI® Cantilevering Saddles 14

 Section I - LPI® U-Bolt..... 15

 Section J - LPI® Mounting Bracket..... 15

 Section K - LPI® Cable Sock 15

 Section L – Downconductors 16

 LPI® High Voltage Shielded Cable 16

 LPI® Copper Tape 17

 LPI® Aluminium Tape 18

 LPI® Stranded Copper Cable..... 18

 Section M - LPI® Cable Ties..... 18

 Section N - LPI® Saddles and Fixings..... 19

 LPI® Saddles..... 19

 LPI® D.C Tape Clip 19

 LPI® Square Tape Clamp 19

 LPI® Oblong Test Clamp 20

 Section O - LPI® Beam Clamp and Cable Support..... 20

 Section P - LPI® Lightning Strike Recorder..... 20

 LPI® Lightning Strike Recorder Tester 21

 Section Q - LPI® Lower Termination Kit..... 21

 Section R - LPI® Denso Tape..... 22

 Section S - LPI® Earthing System..... 22

 LPI® Copper Bonded Earth Rods 22

 LPI® Stainless Steel Earth Rods..... 23

 LPI® Coupling for Copper Bonded and Stainless Steel Threaded Earth Rods 23

 LPI® Copper Tape 23

 LPI® Rod to Tape Clamp Type A..... 24

 Section T - LPI® Inspection Pits 24

 Section U - LPI® Earthing Compounds 25

 LPI® GRIP 25

 LPI® RESLO 25

 LPI® SRIM..... 25

 Section V - LPI® Chemical Ground Rod..... 26

TECHNICAL DATA SHEET

Recommended Earthing Installation..... 27
ISO 9001 & ISO 14001 Certificate 27

TECHNICAL DATA SHEET

Installation Type 1

Installation type 1 illustrates a Guardian system installed on a building roof top (flat roof).

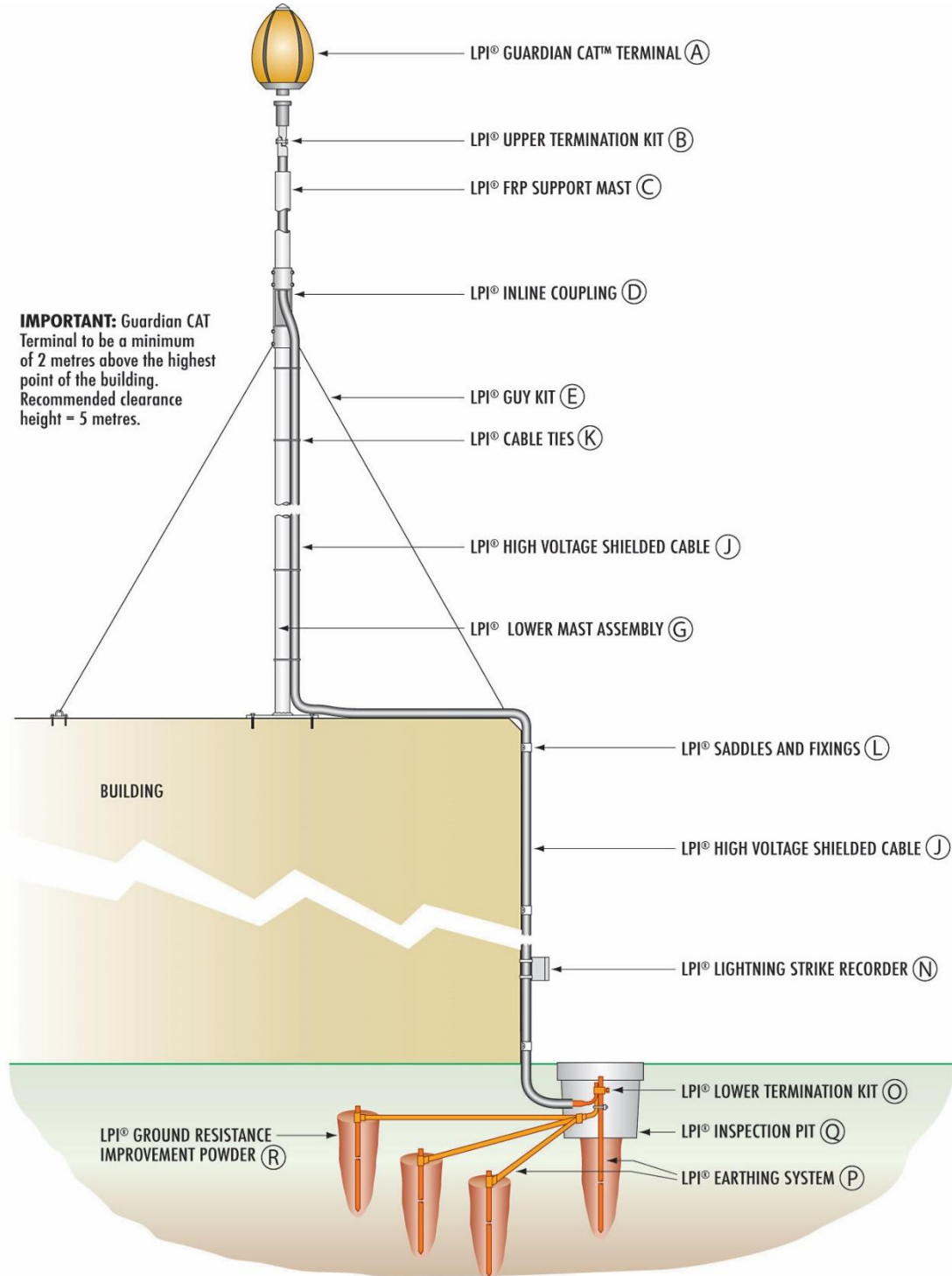

Please refer to page 27 for recommended earthing installation

TECHNICAL DATA SHEET

Installation Type 2

Installation type 2 illustrates a Guardian system cantilevered to the side wall of a building.

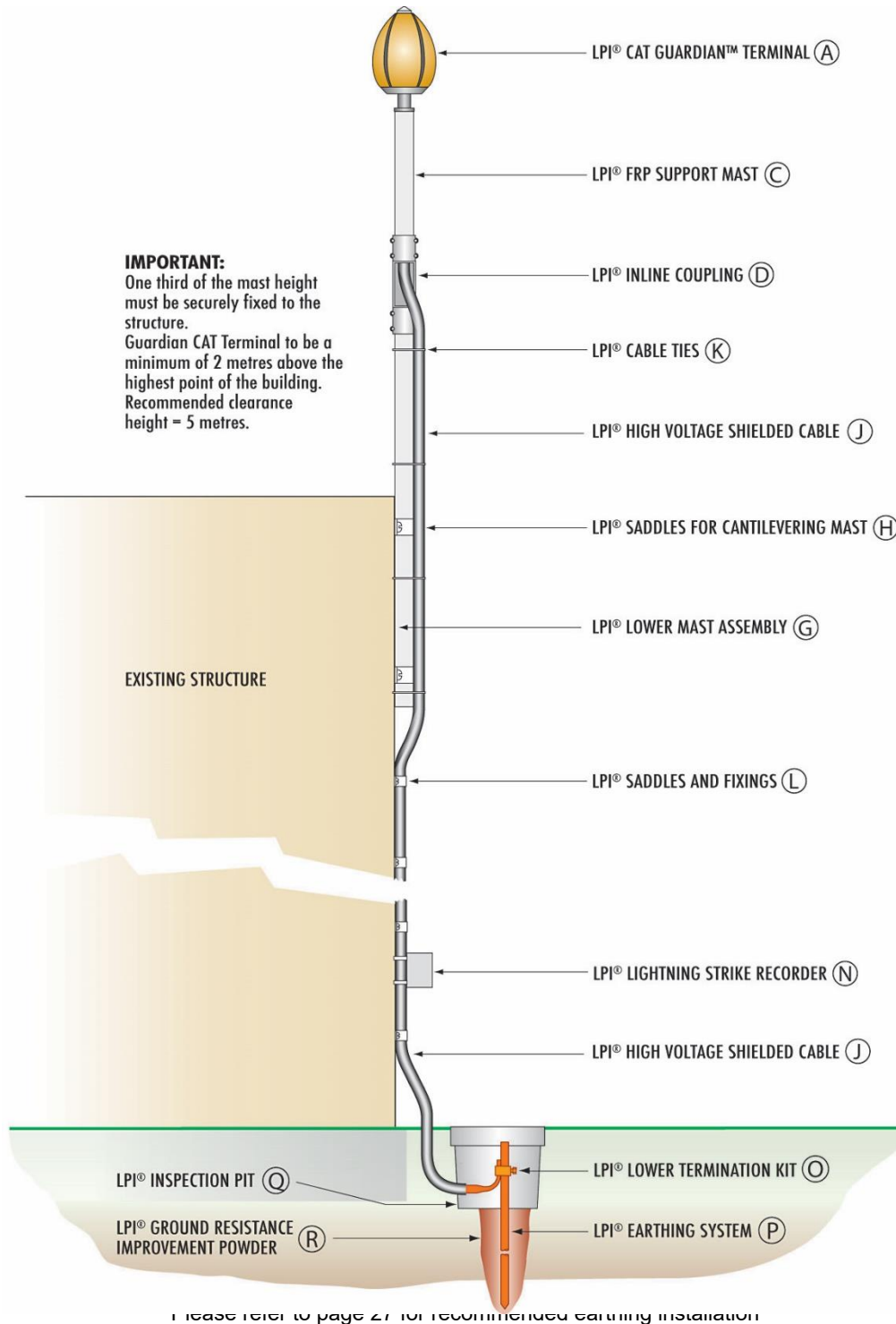

TECHNICAL DATA SHEET

Installation Type 3

Installation type 3 illustrates a Guardian system cantilevered to the top section of a tower.

IMPORTANT:
 One third of the mast height must be securely fixed to the structure.
 Guardian CAT Terminal to be a minimum of 2 metres above the highest point of the tower.
 Recommended clearance height = 5 metres.

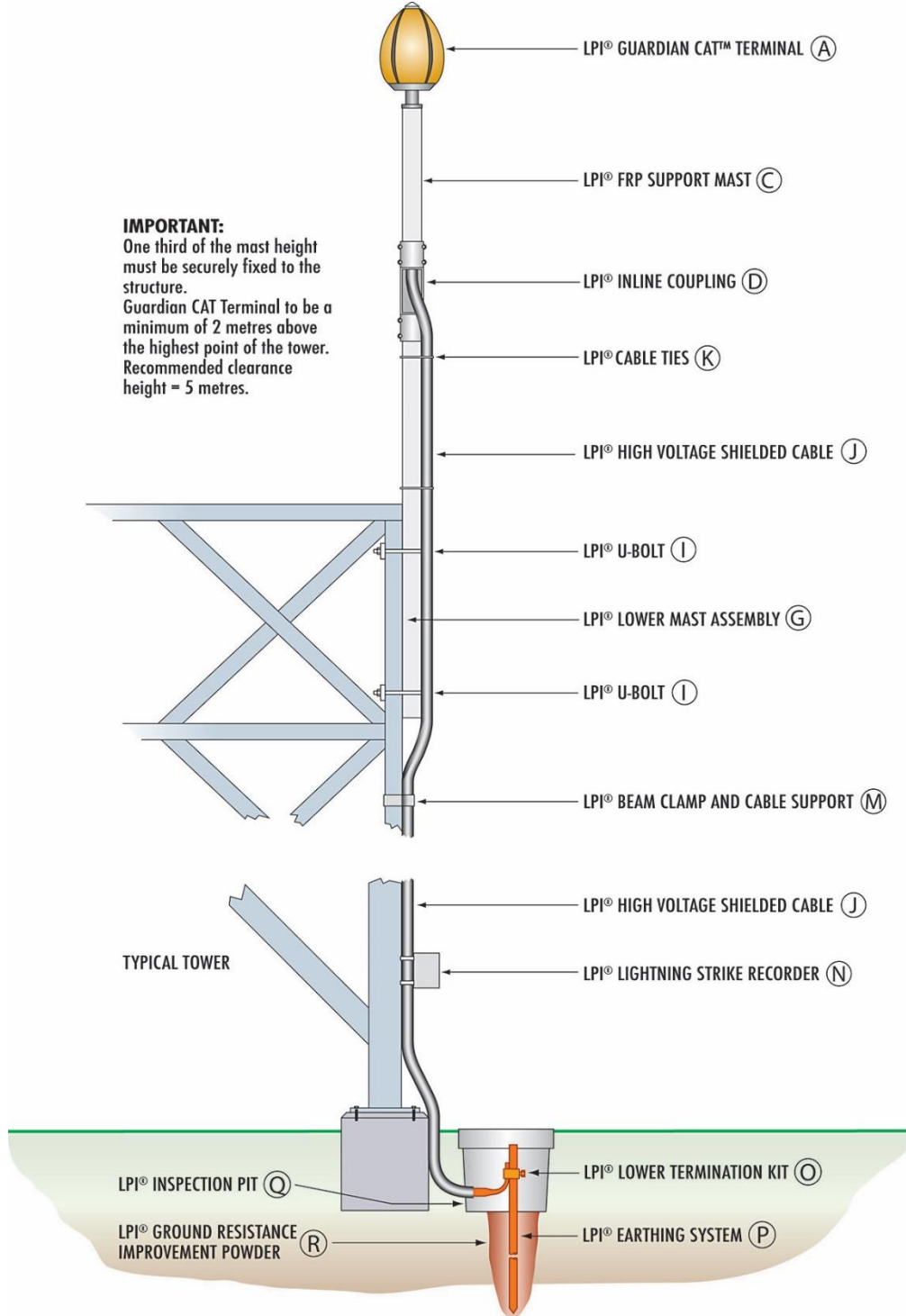

TECHNICAL DATA SHEET

Installation Type 4

Installation type 4 illustrates a Guardian system installed on a building roof top (flat roof) or at ground level.

Note: Multiple guying kits are utilized due to increased mast height.

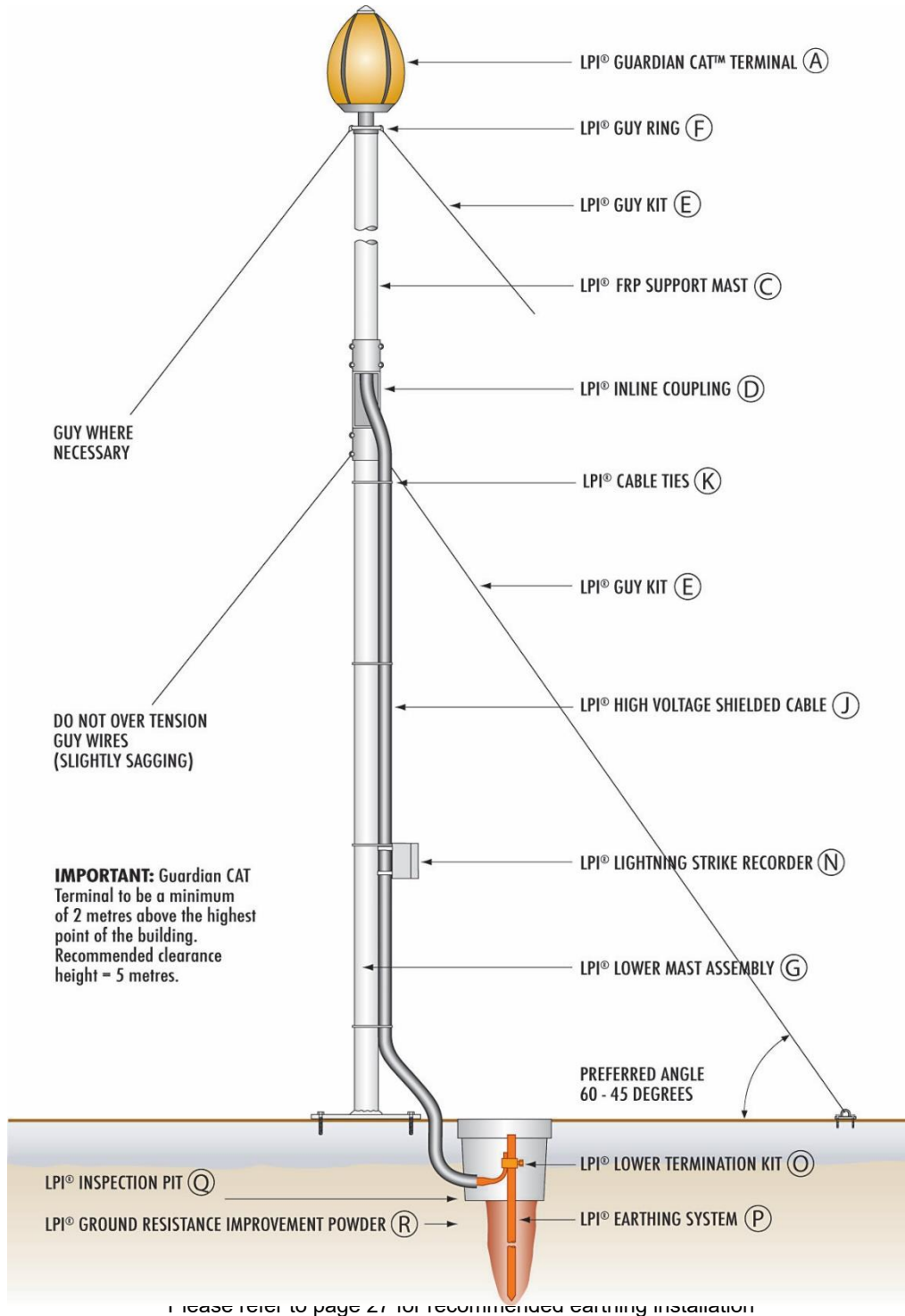

TECHNICAL DATA SHEET

Installation Type 5

Installation type 5 illustrates typical mounting arrangement for cantilevered GI style Guardian Terminal.

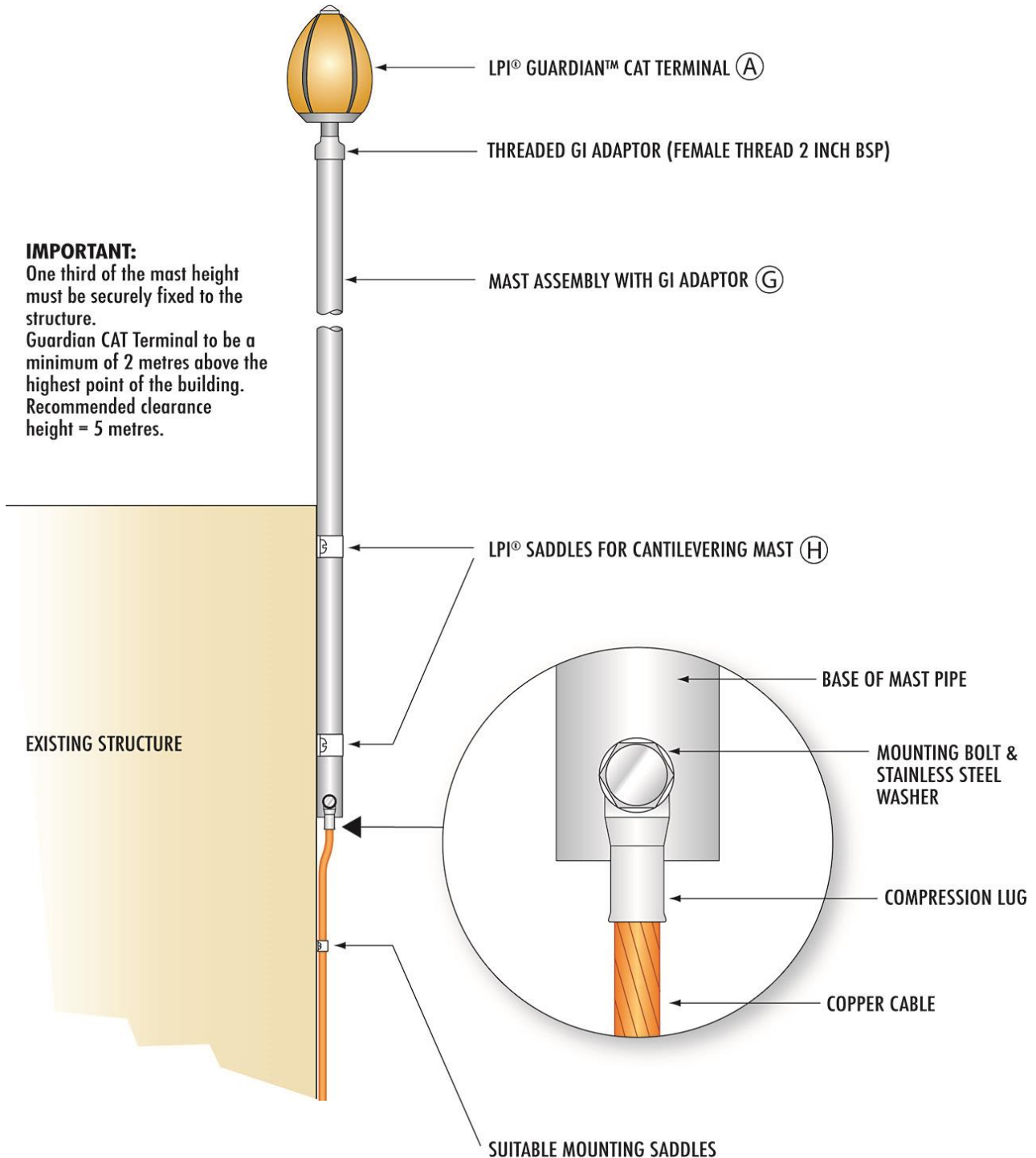

Please refer to page 27 for recommended earthing installation

TECHNICAL DATA SHEET

Section A - LPI[®] Guardian Cat Terminals

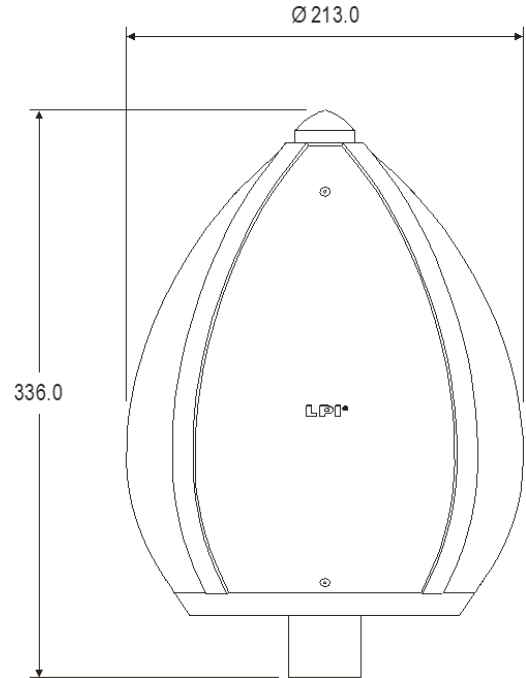
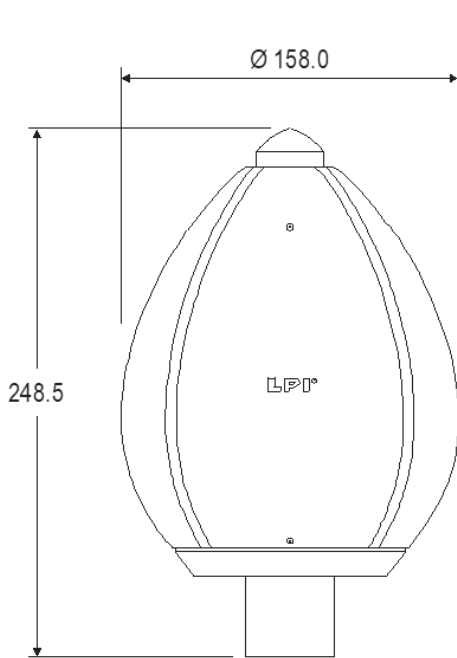

ORDERING CODE	MATERIAL	WEIGHT (KG)	COLOUR	INSULATION MATERIAL
CATI-SS	Stainless steel 316	0.655	Silver	UV rated evoprene
CATII-SS	Stainless steel 316	1.177	Silver	UV rated evoprene
CATIII-SS	Stainless steel 316	1.993	Silver	UV rated evoprene

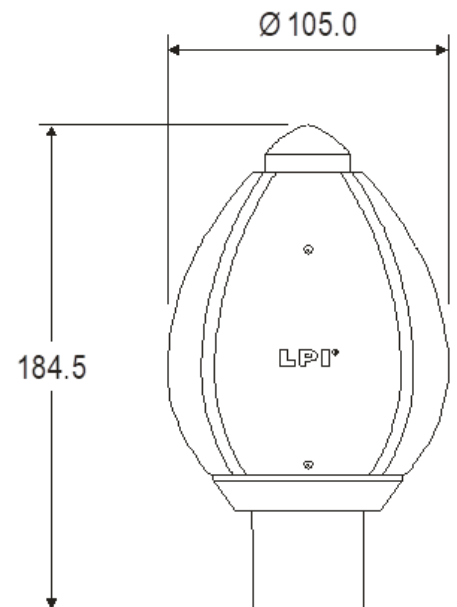

* For connection to 2" GI Pipe add "GI" to end of Ordering Code (See pages 8 & 12 for more detail)

All dimensions are given in mm UNO

TECHNICAL DATA SHEET

LPI® Guardian CAT Terminals

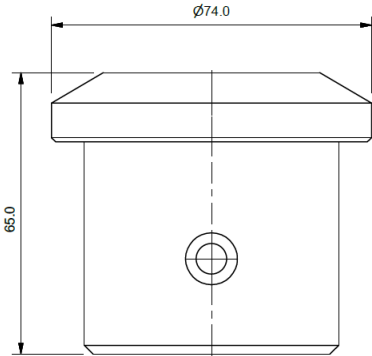
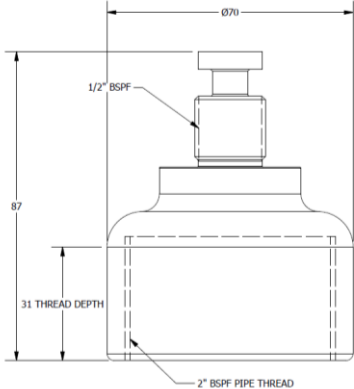
Standard Adaptor	GI Adaptor
<ul style="list-style-type: none"> For use with FRP mast & HVSC Plus downconductor Lug Connection to HVSC Plus completed with upper termination Weight: 0.22 kg 	<ul style="list-style-type: none"> Threaded GI adaptor Female thread 2 inch BSP for connection to GI pipe Weight: 0.22 kg 

Guardian CAT Tester

	<ul style="list-style-type: none"> Spark-over tester designed for testing the Guardian CAT range of terminals Portable tester Visual identification of terminal operation Rechargeable batteries
Ordering Code	AIR TERMINAL TESTER
Description:	LPI® Guardian CAT terminal tester
Construction:	Plastic enclosure
Charger operating voltage:	100 – 240 V
Batteries:	4 x 1.2 V rechargeable NiCad batteries
Dimension:	115 x 90 x 55 mm
Weight:	0.437 kg



TECHNICAL DATA SHEET

Section D - LPI® Inline Coupling

LPI® Inline coupling is a purpose-designed coupling which enables clamping of the FRP mast to the aluminium lower mast. The inline coupling provides 3 guy anchoring points and provides an exit point for the HVSC Plus.

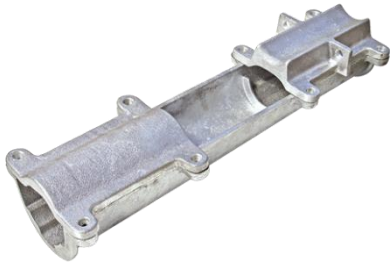

Ordering code	ILCOUPLING
Description:	Inline coupling
Material:	Cast aluminium
Dimension:	550 x 150 x 120 mm
Weight:	2.7 kg
Anchoring points:	3
Max. clamping torque:	55 kg/cm

Section E - LPI® Guy Kit

LPI® non-conductive and stainless steel guy kits are provided in variable lengths to suit specific mast and terminal heights. The purpose designed guying kits are designed for anchoring from a guy ring or an inline coupling.



Ordering Code	GUYKIT-4M	GUYKIT-7M
Description:	Stainless steel fittings and non-conductive synthetic guy wire kits	
Material:	DYNEEMA® is an UHMWPE* fibre, non-conductive, UV stabilised, moisture resistant, chemical inert	
Application:	Designed to provide additional stabilising/securing of mast arrangement where deemed necessary	
Diameter:	4 mm	
Tensile yield strength:	560 kg	
Weight:	0.46 kg	0.53 kg

*UHMWPE – Ultra-High Molecular Weight Polythene



Ordering Code	GUYKIT-4M-SS	GUYKIT-7M-SS
Description:	Stainless steel guy wire kits	
Material:	Stainless steel, grade 316	
Application:	Designed to provide additional stabilising/securing of mast arrangement from the inline coupling only	
Diameter:	3.2 mm	
Tensile yield strength:	450 kg	
Weight:	0.8 kg	1.2 kg

Stainless steel guy kits are not to be used at top section of mast or with guy ring and should be anchored from the inline coupling.

TECHNICAL DATA SHEET

Section F - LPI® Guy Ring

LPI® guy ring provides 3 guy points for mounting between the top section of the FRP mast and the Guardian CAT terminal.



Ordering Code	Guy Ring
Material:	Cast aluminium
Dimension:	110 x 110 x 10 mm
Weight:	0.12 kg
Guy hole diameter:	10 mm

Section G - LPI® Lower Mast Assembly

LPI® uses an aluminium mast as the lower mast assembly due to its high strength and light weight characteristics.



Description	Aluminium Mast
Colour:	Silver
Material:	Aluminium
Inside diameter:	61.9 mm
Outside diameter:	69.9 mm

Length	3 Metres	4 Metres	5 Metres	6 Metres
Weight:	7 kg, 8 kg (with base)	9 kg, 10 kg (with base)	11.7 kg, 12.7 kg (with base)	14.4 kg, 15.4 kg (with base)
No base:	ALUM-3M	ALUM-4M	ALUM-5M	ALUM-6M
With base:	ALUMB-3M	ALUMB-4M	ALUMB-5M	ALUMB-6M
With GI male adaptor:	ALUM3M-MGI	ALUMB4M-MGI	ALUMB5M-MGI	ALUMB6M-MGI

LPI® Guardian GI terminals suitable for use with locally supplied 2" male threaded GI pipe.

Section H - LPI® Cantilevering Saddles

TECHNICAL DATA SHEET

Purpose designed stainless steel saddles for cantilevering the aluminium mast of 69.9 mm outer diameter to flat vertical surface.



Ordering Code	CANTSAD
Description:	70 mm saddles for mounting of aluminium mast (3 per set)
Material:	Stainless steel
Weight:	180 g per saddle, 540 g per set
Dimension:	130 (L) x 70 (W) x 1.2 mm (D)
Hole fixing diameter:	8 mm

Section I - LPI® U-Bolt

LPI® U-Bolt set is specifically designed to allow for the secure clamping of aluminium or FRP mast to tower section or handle rail.



Ordering Code	U-Bolt
Description:	U-Bolt, 2 per set
Material:	U-Bolt: stainless steel, Plate: aluminium
Weight:	0.75 kg per U-Bolt, 1.5 kg per set
Dimension:	80 mm diameter, 170 mm length

Section J - LPI® Mounting Bracket

LPI® Offset brackets are designed for the offset cantilevering of aluminium support masts.



Ordering Code	Mounting Bracket
Description:	Offset bracket
Colour:	Silver
Material:	Stainless steel, 316
Nominal clamping OD:	70 mm
Weight	1 kg

Section K - LPI® Cable Sock

LPI® Cable sock is designed for the mounting support of the HVSC Plus downconductor when installing a free standing mast arrangement.

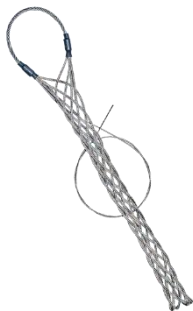

Ordering Code	Cable Sock
Description:	Cable sock for HVSC Plus support
Material:	Two-ply galvanised steel wire strand
To grip cable diameter:	28-40 mm
Grip length:	600 mm
Max. pull approx, (kn)	24

TECHNICAL DATA SHEET

Section L – Downconductors

LPI[®] High Voltage Shielded Cable



Withstand Voltage of ≥ 500 kV

LPI's "High Voltage Shielded Cable" (HVSC Plus) is a purpose-designed, high-integrity, low-impedance cable that is used to safely convey lightning currents to earth with minimal risk of side flashing or structure electrification. The design of the HVSC Plus incorporates carefully selected dielectric components to ensure optimum performance under the impulse or "transient" voltages and currents imposed by lightning discharges.

LPI's new HVSC Plus provides improved features as a dedicated insulated lightning downconductor:

- Double the voltage withstand performance of past versions;
- 35% reduction in the mass per unit length of the cable;
- Improved manufacturing consistency via a continuous "triple extrusion" process;
- Reduced voltage stress via thin, semi-conductive screen layers; and
- Improved material parameters and performance.

The design of the cable is based on the optimisation of all of the key parameters associated with dealing with lightning discharges and the consequent voltage and current transients, including impedance, inductance, capacitance, insulation thickness (withstand voltage) and all of the relevant lightning statistics, plus practical aspects such as size, flexibility and mass.

Figure 1: Construction of the HVSC Plus lightning downconductor cable.

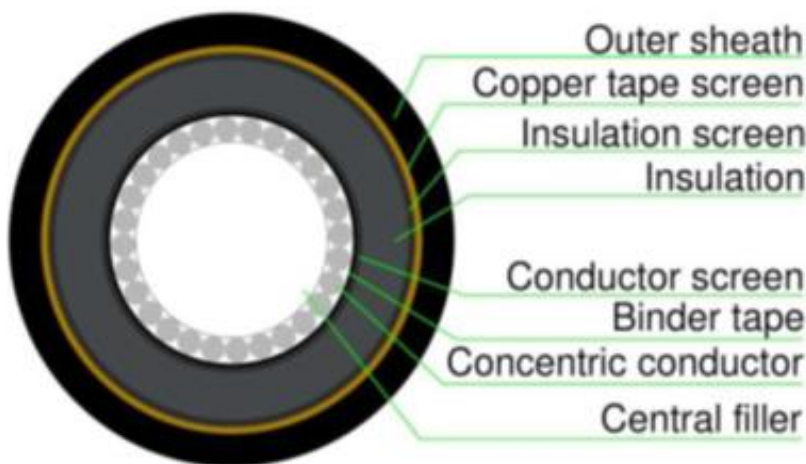

HVSC Plus has been tested by a certified, independent high voltage laboratory located at Monash University, Australia.

This Test Report is available on request to info@lpi.com.au or on our website www.lpi.com.au

Product Ordering Code: HVSCPLUS-PM or HVSCPLUS-500

Physical Specifications of HVSC Plus:

TECHNICAL DATA SHEET

Mass per unit length	1.34 kg/m
Construction	Triple extruded
Concentric conductor material	Aluminium
Concentric conductor XSA	≥ 50 mm ²
Insulation	5 mm (nominal) of XLPE
Metallic screen	Copper tape
Outer sheath	3 mm (nominal) of PVC, UV Stabilised
Cable diameter	36 mm
Min. bending radius <i>before</i> installation	430 mm
Min. bending radius <i>after</i> installation	358 mm

Electrical Specifications of HVSC Plus:

Conductor DC resistance @ 20°C	0.641 Ω/km
Conductor DC resistance @ 90°C	0.821 Ω/km
Insulation resistance @ 20°C	5000 MΩ
Inductance	93 nH/m
Capacitance	285 pF/m
Impedance	18 Ω
Withstand voltage (1.2/50 μs impulse)	≥ 500 kV

LPI® Copper Tape

LPI® 25 mm x 3 mm soft drawn copper tape is manufactured using the latest, European developed extrusion technologies. LPI® FL6T253C is a high-quality tape which provides our customers with a guaranteed copper purity of 99.95%. FL6T253C

TECHNICAL DATA SHEET

is ideal for use as a conventional means of conveying lightning energy to ground.



Ordering Code	FL6T253C
Description:	Copper tape 25 x 3 mm (soft drawn)
Material:	99.95% Copper
Dimension:	25 (Width) x 3 mm (Thickness)
Weight:	0.67 kg per metre
Electrical conductivity:	Minimum 100% I.A.C.S
Standard:	BS1432
Tensile strength:	210 - 250 N/mm ²
Package:	Supplied in pancake coil form (50 m per coil)

NFC 17-102 (2011)/EN 50164-2 has a requirement for copper and aluminium downconductors to have a cross-sectional area of 50 mm.

LPI® Aluminium Tape



Ordering Code	FL6T253A
Description:	Aluminium tape 25 x 3 mm (soft drawn)
Material:	Aluminium
Dimension:	25 (Width) x 3 mm (Thickness)
Weight:	0.2 kg per metre
Electrical conductivity:	>60% I.A.C.S
Package:	Supplied in pancake coil form (50 m per coil)

NFC 17-102 (2011)/EN 50164-2 has a requirement for copper and aluminium downconductors to have a cross-sectional area of 50 mm.

LPI® Stranded Copper Cable

LPI® soft drawn stranded copper cable is ideal for use as a conventional means of conveying lightning energy to ground. The cable is manufactured in compliance to BS6360.



Ordering Code	SCC70
Description:	Stranded copper cable 70 mm ²
Material:	Copper
Cross section/diameter:	70 mm ² / 2.14 mm Dia
Weight:	0.62 kg per metre
Stranding No.	19

Section M - LPI® Cable Ties

LPI® Cable ties are designed for securing the HVSC Plus downconductor to structures and mast assembly.

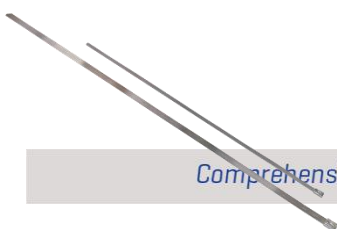

Ordering Code	SS-CABTIE-STD	SS-CABTIES-L
Description:	Cable ties	

TECHNICAL DATA SHEET

Material:	Stainless steel	
Length:	360 mm	520 mm
Width:	7.9 mm	7.9 mm
Weight	10 g	10 g

Section N - LPI® Saddles and Fixings

LPI® Saddles

LPI® SAD FIX are specially designed for securing of HVSC Plus downconductor to structures.



Ordering Code	SAD FIX
Description:	Saddles and fixings
Material:	Stainless steel, grade 304
Dimension:	90 mm long, 1.2 mm thick
Fixing hole diameter:	7 mm
Weight:	40 g

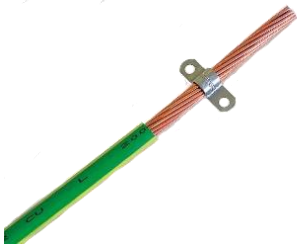

Ordering Code	SAD FIX-70
Description:	Saddles to suit 70 mm ² cable
Material:	Stainless steel, grade 316
Dimension:	44 mm long, 1 mm thick
Fixing hole diameter:	7 mm
Weight:	5 g

LPI® D.C Tape Clip

LPI® D.C Tape Clips are designed for the securing of Copper or Aluminium Tape to structures.



Ordering Code	FL3DCTC253C	FL3DCTC253A
Description:	D.C tape clip to suit 25 x 3 mm tape	
Material:	High strength copper alloy	High strength aluminium alloy
Conductor size:	25 x 3 mm	
Weight:	43 g	17 g

LPI® Square Tape Clamp

Ordering Code	FL4STC253C	FL4STC253A
Description:	Square tape clamp to suit 25 x 3 mm tape	

TECHNICAL DATA SHEET

LPI® Square tape clamps are designed to allow for the 2- and 4-way routing of copper and



Material:	High strength copper alloy	High strength aluminium alloy
Conductor size:	25 x 3 mm	
Weight:	168 g	78 g

aluminium downconductors.

LPI® Oblong Test Clamp

LPI® Oblong test clamp are designed to allow for the disconnection of copper and aluminium downconductors for testing purposes.



Ordering Code	FL4OTC253C	FL4OTC253A
Description:	Oblong test clamp to suit 25 x 3 mm tape	
Material:	High strength copper alloy	High strength aluminium alloy
Conductor size:	25 x 3 mm	
Weight:	126 g	118 g

Section O - LPI® Beam Clamp and Cable Support

LPI® Beam clamp and cable support are specifically designed for the securing of the HVSC Plus downconductor to tower legs.



Ordering Code	BEAM CLAMP / CABLE SUPPORT - HVSC
Description:	Beam clamp and cable support
Material:	Stainless steel, polymer
Dimension:	60 x 60 x 50 mm
Fixing hole diameter:	38 mm
Weight:	180 g

Section P - LPI® Lightning Strike Recorder

LPI® Lightning Strike Recorder (LSR2) is a lightning strike counter. The LSR2 is simply mounted at any location along the

TECHNICAL DATA SHEET

downconductor route. Its purpose is to record the number of strikes captured and conveyed by the downconductor.



Ordering Code	LSR2
Description:	Lightning strike recorder
Current sensitivity:	1500 A 8/20 μ s impulse
Operating range:	Min. 1500 A and Max. 220 kA 8/20 μ s
Display:	Mechanical 7 digits display (not re-settable).
Dimension:	100 mm (B) x 100 mm (H) x 55 mm (D)
Weight:	0.56 kg
Mounting:	Releasable UV resistant plastic cable ties suitable for up to \varnothing 40 mm cable or 50 x 5 mm flat tape
Construction:	Polycarbonate enclosure
Colour:	Light grey & blue
Environment:	IP 67 (IEC 529)
Operating temperature:	-15°C to 65°C

LPI® Lightning Strike Recorder Tester

LPI® Lightning strike recorder tester is a high-current injection device designed to trigger a reading on an LPI Lightning Strike Recorder (LSR1).



Section Q - LPI® Lower Termination Kit

LPI® Lower termination kit provides accessories and tools for the termination of the HVSC Plus lower end to the dedicated lightning earth.



Ordering Code	LSR1-TESTER MKII
Description:	Lightning strike recorder tester
Impulse output:	2 kA peak simulated lightning impulse
Open circuit output:	55 Volts
Time between impulses:	20 seconds
Display:	Red "Testing" LED indicator
Dimensions:	190 mm (L) x 100 mm (W) x 35 mm (H)
Mounting:	Portable unit, no mounting required
Construction:	Polycarbonate Enclosure, IP 30 rating
Colour:	Light grey
Weight:	0.58 kg
Working temperature:	-15°C to 65°C
Batteries:	8 x AA 2000 mAh NiMH rechargeable Recharge time up to 16 hours

TECHNICAL DATA SHEET

Ordering Code	LTERMKIT-MK3
Description:	Lower termination kit
Pack Dimensions:	270 mm (B) x 100 mm (H) x 40 mm (D)
Weight:	515 g
Contents:	1 x 95 mm crimp lug 1 x waterproofing tape 1 x earth rod clamp 2 x warning labels 1 x insulation friction cutting tool

Suitable for use with conventional downconductors as required.

Section R - LPI[®] Denso Tape

Denso Tape is used to waterproof earthing installations and prevent corrosion.



Ordering Code	DENSO-25mm	DENSO-50mm
Description:	Waterproofing tape	
Material:	Synthetic fabric, impregnated and coated with a neutral petrolatum compound	
Pack:	25 mm x 10 m	50 mm x 10 m
Weight:	400 g	800 g

**Section S - LPI[®] Earthing System
LPI[®] Copper Bonded Earth Rods**

LPI[®] Copper-bonded earth rods are made from high-tensile low-carbon steel and each rod is manufactured by molecularly bonding 99.9% pure electrolytic copper to the low-carbon steel core in accordance with national and international standards such as BS6651, BS7430 and UL467. Threads are rolled onto the rod, ensuring an even copper covering which eliminates the risk of chipping whilst driving.

TECHNICAL DATA SHEET



Other sized rods available.

Ordering Code	CBER1214
Description:	Threaded copper bonded earth rod
Material:	Carbon steel bonded with copper
Length:	1.2 m
Rod diameter (actual):	14.3 mm
Threaded diameter:	5/8" UNC
Weight:	1.54 kg

LPI® Stainless Steel Earth Rods

LPI® Solid stainless steel earth rods are manufactured using 316 grade stainless steel and are highly resistant to corrosion. Stainless steel rods are best used for earthing installations where the problem of galvanic corrosion may take place between dissimilar metals buried in close proximity to each other and where highly corrosive soil conditions exist. All solid stainless steel earth rods manufactured by LPI are supplied with external threads.



Other sized rods available.

Ordering Code	SSER1215
Description:	Threaded stainless steel earth rod
Material:	316 grade stainless steel
Length:	1.2 m
Rod Diameter (Actual):	15.8 mm
Threaded Diameter:	5/8" UNC
Weight:	1.90 kg

LPI® Coupling for Copper Bonded and Stainless Steel Threaded Earth Rods

Whether connecting rod-to-rod or driving stud-to-rod the high strength copper alloy coupling is counter-bored to protect the earth threads from damage and subsequent corrosion.



Ordering Code	LEH-58R	LEH-58R-SS
Description:	Coupling for threaded Copper bonded earth rod 5/8"	Coupling for threaded Stainless steel earth rod 5/8"
Material:	High strength copper alloy	316 stainless steel
Thread type:	5/8" UNC	
Weight:	106 g	113 g

LPI® Copper Tape

LPI® 25 x 3 mm soft drawn copper tape is manufactured using the latest European developed extrusion technologies. LPI® FL6T253C is a high-quality tape which provides our customers with a guaranteed copper purity of 99.95%. Flat copper tape in comparison to stranded copper cable is considered as the most efficient conductor for the transfer of lightning energy to the ground mass. Flat tape provides greater surface contact with the surrounding soil which assists greatly in the dissipation of the lightning energy.



TECHNICAL DATA SHEET

Ordering Code	FL6T253C
Description:	Copper tape 25 x 3 mm (soft drawn)
Material:	99.95% Copper
Dimension:	25 (Width) x 3 mm (Thickness)
Weight:	0.67 kg per metre
Electrical conductivity:	Minimum 100% I.A.C.S
Standard:	BS1432
Tensile strength:	210 - 250 N/mm ²
Package:	Supplied in pancake coil form (50 m per coil)

LPI® Rod to Tape Clamp Type A

LPI® Rod to tape clamp provides a conductive and mechanically secure connection when installing a lightning protection earth encompassing flat copper tape and copper bonded earth rods.



Ordering Code	RTC253
Description:	Rod to tape clamp to suit 14-17 mm Dia rod & 25 x 3 mm tape
Material:	High strength copper alloy
Rod Diameter:	14-17 mm
Conductor size:	25 x 3 mm
Weight:	120 g

Section T - LPI® Inspection Pits

LPI® Inspection pits provide a secure and user-friendly access point for maintenance purposes and the periodical measurement of electrical resistance of a buried earthing system. In order to complete routine measurements of electrical resistance, simply remove the lid from the installed earth pit and connect a lead from the resistance meter to the earthing conductor.

Ordering Code	EPIT-P
Description:	Polymer earth pit
Material:	Polymer

TECHNICAL DATA SHEET



Dimension:	250 mm (top) x 180 mm (base) x 210 mm (deep)
Weight:	1.9 kg
Strength:	Withstand up to 5 tonnes

Section U - LPI[®] Earthing Compounds
LPI[®] GRIP

LPI[®] Ground Resistance Improvement Powder (GRIP) is a premium product designed to reduce soil resistivity in the poorest soil conditions. When GRIP is mixed with water and poured onto the earthing system and surrounding soil, the powder and water react to form a gelatinous mass which will not reduce, contract or separate from the earth electrodes its surrounds.



Ordering Code	GRIP-10	GRIP-40
Description:	Ground resistance improvement powder	
Application:	To assist in achieving an earth resistance of less than 10 Ohms	
Weight:	Part A = 5 kg Part B = 5 kg	Part A = 20 kg Part B = 20 kg

LPI[®] RESLO

LPI[®] RESLO-20 is a low-resistance, non-corrosive, bentonite-based earth enhancing compound which is supplied in easy-to-handle 20 kg bags.



Ordering Code	RESLO-20
Description:	Resistance lowering compound – 20 kg bag
Application:	To assist in achieving an earth resistance of less than 10 Ohms
Weight:	20 kg

LPI[®] SRIM

TECHNICAL DATA SHEET

LPI[®] SRIM-20 is a carbon based earth enhancing compound which is supplied in 20kg bags. Designed for use in all soil conditions, SRIM offers an economical solution to improve and maintain the integrity of any earthing system.



Ordering Code	SRIM-20
Description:	Carbon based resistance lowering material – 20 kg bag
Application:	To lower earth electrode system resistance and impedance
Weight:	20 kg

Section V - LPI[®] Chemical Ground Rod

LPI[®] Chemical ground rod provides a low-impedance earth to effectively dissipate lightning and electrical fault currents. The chemical ground rod is ideal in situations where space is restricted and normal lightning earths such as radial and grid-type systems cannot be installed.

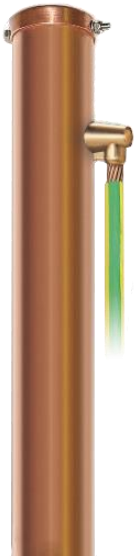

Ordering Code	CHEMROD-2M	CHEMROD-3M
Length:	2 m	3 m
Diameter:	63.5 mm	
Copper composition:	99.9% minimum	
Standard:	Australian Standard AS1432	
Melting point:	1083°C	
Specific heat capacity:	0.385 kJ (kg.K)	
Electrical conductivity (Annealed):	75-90% I.A.C.S.	
Wall thickness:	1.6 mm	
Copper:	Hard-drawn	
Cap:	Removable type with air breather holes	
Drainage holes:	4.5 mm diameter, provided every 40 cm for the length of the rod	
Mineral salts:	Pre-filled from factory with non-hazardous natural electrolytic salts	
Pigtail:	70 mm stranded copper cable, pre-welded from factory to allow for connection to earthing system	
Weight:	12 kg (CHEMROD) 40 kg (RESLO)	21 kg (CHEMROD) 60 kg (RESLO)

TECHNICAL DATA SHEET

Recommended Earthing Installation

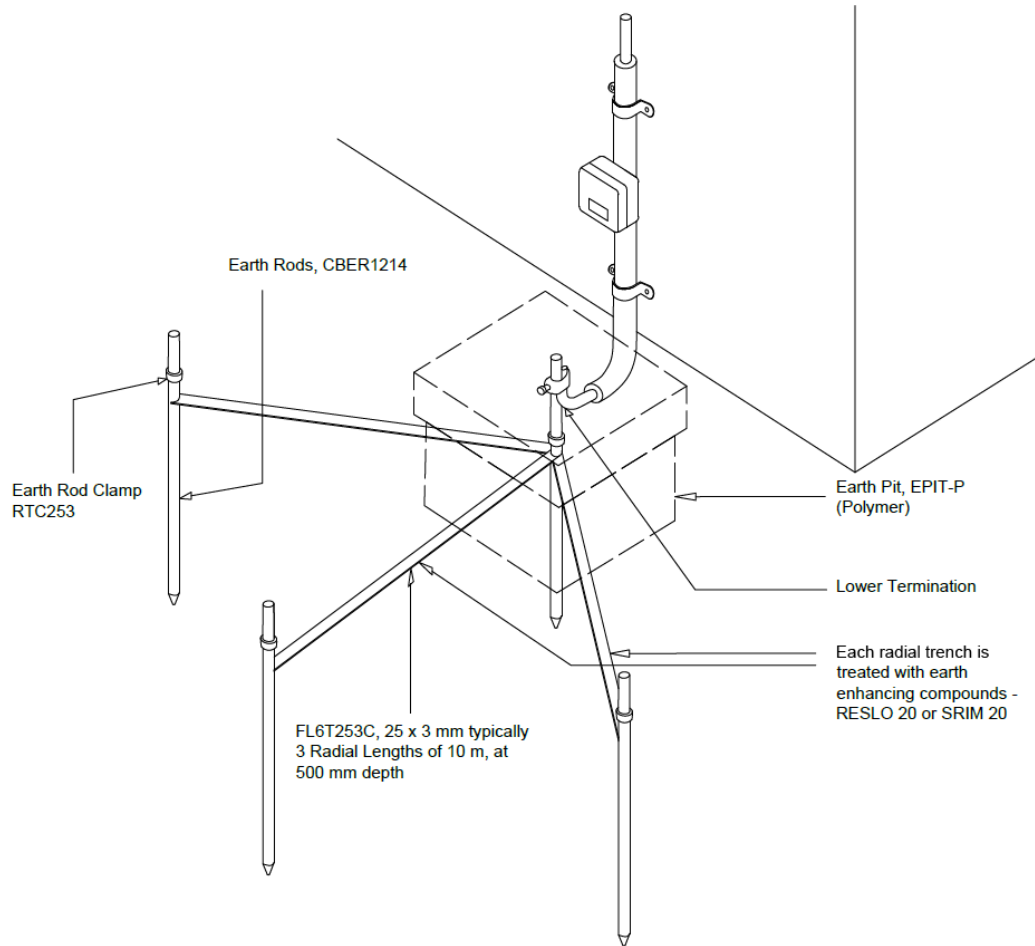

This type of radial earth is recommended for installation as a lightning protection earth.

ISO 9001 & ISO 14001 Certificate

Lightning Protection International Pty Ltd operates a certified management system that complies with the requirements of AS/NZS ISO9001:2008. Certificate can be provided on request.

